

Smarowniczki kulkowe ciśnieniowe z główką stożkową – kątowe 45° i 67°

Lubricating nipple – cone type; angled version 45°
and 67°

wg **DIN 71412 B**
acc. to DIN 71412 B

PN 86003

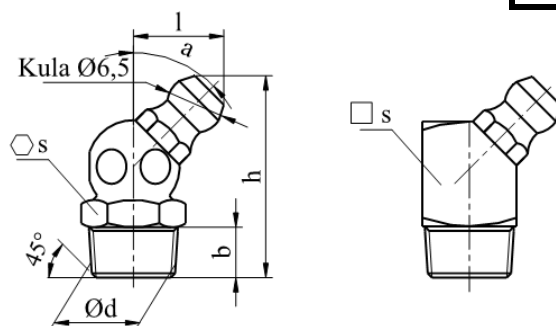

UMETA

Typ H2

Zastosowanie

Smarowniczki kulkowe przeznaczone są do smarowania wraz ze smarownicami ręcznymi oraz mechanicznymi. Połączenie smarowniczki z odpowiednią końcówką zaciskową smarownicy jest mocne, dzięki czemu ten system smarowy zapewnia bez naciskowy sposób smarowania trudno dostępnych punktów smarowych.

Application

Lubricating nipples are suitable for lubricating with handled lubricating power presses or for force lubricating power presses. The connection with the coupler nozzle of the lubricating power press is form conclusive for this reason lubrication equipment without pressures in sloping position are possible for difficult of access lubricating places.

Wymiary

Dimensions

$d^{1)}$	h	b	k	α		s	Numer kat. Art. No.			
							stal, oc. biały steel, zinc plated	stal nierdz. A1 (1.4305) stainless steel A1 (1.4305)	stal kwasoodp. A4 stainless steel A4	mosiądz brass
M5x0,8	23,5	5,5	10,5	45°	9	⬡	1200901	-	-	-
M6x0,75	20,5	5,5	10,5	45°	9	⬡	1204503	-	-	-
	23,5	5,5	10,5	45°	9	⬡	1200903	-	-	-
M6x1,0	20,5	5,5	10,5	45°	9	⬡	1204504	-	-	-
	23,5	5,5	10,5	45°	9	⬡	1209004	1220904	1240904	1210904
	17,5	5,5	12,3	67°	9	⬡	1404504	-	-	-
	20,5	5,5	12,2	67°	9	⬡	1400904	-	-	-
M7x1,0	23,5	5,5	10,5	45°	9	⬡	1200905	-	-	-
M8x0,75	23,5	5,5	10,5	45°	9	⬡	1200906	-	-	-
M8x1,0	20,5	5,5	10,5	45°	9	⬡	1204507	-	-	-
	23,5	5,5	10,5	45°	9	⬡	1200907	1220907	1240907	1210907
	17,5	5,5	12,3	67°	9	⬡	1404507	-	-	-
	20,5	5,5	12,2	67°	9	⬡	1400907	-	-	-

¹⁾ – gwint stożkowy

¹⁾ - tapered thread

20.04.2017

1/3



ARGIP

www.argip.com.pl

tel. +48 61 872 66 02

fax +48 61 872 66 00

Kopiowanie i rozpowszechnianie bez zezwolenia zabronione
Copying and distribution prohibited without permission

Smarowniczki kulkowe ciśnieniowe z główką stożkową – kątowe 45° i 67°

Lubricating nipple – cone type; angled version 45°
and 67°

wg **DIN 71412 B**

acc. to DIN 71412 B

PN 86003

Wymiary c.d.

Dimensions cont.

$d^{1)}$	h	b	k	α	s	Numer kat. Art. No.				
						stal, oc. biały steel, zinc plated	stal nierdz. A1 (1.4305) stainless steel A1 (1.4305)	stal kwasoodp. A4 stainless steel A4	mosiądz brass	
M8x1,25	20,5	5,5	10,5	45°	9	□	1204508	-	-	-
	23,5	5,5	10,5	45°	9	⊕	1200908	1220908	-	1210908
	20,5	5,5	12,2	67°	9	⊕	1400908	-	-	-
M10x1,0	20,5	5,5	11	45°	11	□	1204709	-	-	-
	25	5,5	11,5	45°	11	⊕	1201109	1221109	1241109	1211109
	26	7	11,5	45°	11	⊕	5245085	-	-	-
	47	7	11	45°	11	□	5242088	-	-	-
	25	5,5	11,5	67°	11	⊕	1401109	-	-	-
M10x1,25	25	5,5	11,5	45°	11	⊕	1201110	-	-	-
M10x1,5	25	5,5	11,5	45°	11	⊕	1201111	1221111	-	-
M12x1,0	22,5	6,5	12	45°	14	⊕	1201412	-	-	-
M12x1,5	22,5	6,5	12	45°	14	⊕	1201414	-	-	-
M12x1,75	22,5	6,5	12	45°	14	⊕	1201415	-	-	-
M14x1,5	22,5	6,5	12	45°	14	⊕	1201417	-	-	-
M16x1,5	25,5	7	13,5	45°	17	⊕	1201719	-	-	-
R1/8, 1/8-28 BSP	20,5	5,5	11	45°	11	□	1204756	-	-	-
	25	5,5	11,5	45°	11	⊕	1201156	1221156	1241156	1211156
	28,5	9	11,5	45°	11	⊕	5241236	-	-	-
	36	5,5	11	45°	11	□	5242087	-	-	-
	25	5,5	11,5	67°	11	⊕	1401156	-	-	-
R1/4, 1/4-19 BSP	22,5	6,5	12	45°	11	⊕	1201457	1221457	1241457	1211457
R3/8, 3/8-19 BSP	25,5	7	13,5	45°	17	⊕	1201758	-	-	-
1/8-27 NPT/PTF	20,5	5,5	11	45°	11	□	1204767	-	-	-
	27	7	11,5	45°	11	⊕	5242104	-	-	-
	24	7	14	45°	11	⊕	5242105	-	-	-

20.04.2017

2/3



ARGIP

www.argip.com.pl

tel. +48 61 872 66 02

fax +48 61 872 66 00

Kopiowanie i rozpowszechnianie bez zezwolenia zabronione
Copying and distribution prohibited without permission

¹⁾ – gwint stożkowy

¹⁾ - tapered thread

Smarowniczki kulkowe ciśnieniowe z główką stożkową – kątowne 45° i 67°

Lubricating nipple – cone type; angled version 45°
and 67°

wg **DIN 71412 B**

acc. to **DIN 71412 B**

PN 86003

Wymiary c.d.

Dimensions cont.

<i>d</i> ¹⁾	<i>h</i>	<i>b</i>	<i>k</i>	<i>α</i>	<i>s</i>	Numer kat. Art. No.				
						stal, oc. biały steel, zinc plated	stal nierdz. A1 (1.4305) stainless steel A1 (1.4305)	stal kwasoodp. A4 stainless steel A4	mosiądz brass	
1/4-18 NPT/PTF	22,5	6,5	12	45°	14	⊗	1201468	-	-	-
1/4-26 BSF	23,5	5,5	10,5	45°	9	⊗	1200944	1220944	-	-
	20,5	5,5	12,2	67°	9	⊗	1400944	-	-	-
1/4-28 NF/UNF /SAE	23,5	5,5	10,5	45°	9	⊗	1200937	1220937	-	1210937
	20,5	5,5	12,2	67°	9	⊗	1400937	-	-	-
1/4-BSW	23,5	5,5	10,5	45°	9	⊗	1200950	-	-	-
5/16- 22BSF	23,5	5,5	10,5	45°	9	⊗	1200945	-	-	-
	20,5	5,5	12,2	67°	9	⊗	1400945	-	-	-
5/16-24NF /UNF/SAE	23,5	5,5	10,5	45°	9	⊗	1200938	1220938	-	1210938
	20,5	5,5	12,2	67°	9	⊗	1400938	-	-	-
5/16-BSW	23,5	5,5	10,5	45°	9	⊗	1200951	-	-	-
3/8-18NPT /PTF	25,5	7	13,5	45°	17	⊗	1201769	-	-	-
3/8-BSF	25,5	5,5	11,5	45°	11	⊗	1201146	-	-	-
	25	5,5	11,5	67°	11	⊗	1201139	-	-	-
3/8-24NF /UNF/SAE	25	5,5	11,5	67°	11	⊗	1401139	-	-	-
3/8-BSW	25	5,5	11,5	45°	11	⊗	1201152	-	-	-
1/2-20UNF /NF/SAE	22,5	6,5	12	45°	14	⊗	1201440	-	-	-

¹⁾ – gwint stożkowy

¹⁾ - tapered thread

Materiał:

Stal o klasie własności mechanicznych 5.8 wg ISO 898-1
Powierzchnia wg DIN 50133 o twardości min 550 HV
Głębokość hartowania: 0,08 do 0,15mm
Powłoki galwaniczne wg DIN 297-9 : A3F

Material:

Steel of 5.8 property class
Surface acc. to DIN 50133 – 550HV hardness
Depth of hardening: 0,08 to 1,15 mm
Electroplating acc. to DIN 267-9: A3F

Przykład oznaczenia smarowniczki kulkowej z gwintem M8x1, kątownej 45° forma B, wykonanej ze stali węglowej:

Smarowniczka DIN 71412 – B- 45° - M8x1 – St

20.04.2017

3/3



ARGIP

www.argip.com.pl

tel. +48 61 872 66 02

fax +48 61 872 66 00

Kopiowanie i rozpowszechnianie bez zezwolenia zabronione
Copying and distribution prohibited without permission

Example designation of lubricating nipples with thread M8x1, angled version 45° form B, made of steel:

Lubricating nipples DIN 71412 – B-45°- M8x1 - St

