

Smarowniczki kulkowe ciśnieniowe z główką stożkową – kątowe 90°

wg **DIN 71412 C**
acc. to DIN 71412 C

PN 86003

Lubricating nipples – cone type; angled version 90°

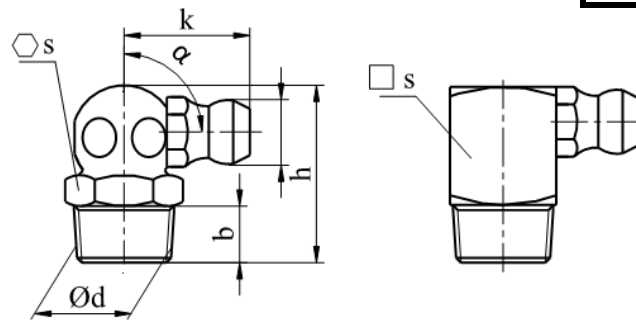

Typ H3

Zastosowanie

Smarowniczki kulkowe przeznaczone są do smarowania wraz ze smarownicami ręcznymi oraz mechanicznymi. Połączenie smarowniczki z odpowiednią końcówką zaciskową smarownicy jest mocne, dzięki czemu ten system smarowy zapewnia bez naciskowy sposób smarowania trudno dostępnych punktów smarowych.

Application

Lubricating nipples are suitable for lubricating with handled lubricating power presses or for force lubricating power presses. The connection with the coupler nozzle of the lubricating power press is firm and conclusive for this reason lubrication equipment without pressures in sloping position are possible for difficult of access lubricating places.

Wymiary

Dimensions

$d^{1)}$	h	b	k	α	s	Numer kat. Art. No.				
						stal, oc. biały steel, zinc plated	stal nierdz. A1 (1.4305) stainless steel A1 (1.4305)	stal kwasoodp. A4 stainless steel A4	mosiądz brass	
M5x0,8	18	5,5	13	90°	9	⊕	1300901	-	-	-
M6x0,75	18	5,5	14	90°	9	□	1304503	-	-	-
	18	5,5	13	90°	9	⊕	1300903	-	-	-
M6x1,0	18	5,5	14	90°	9	□	1304504	-	-	-
	18	5,5	13	90°	9	⊕	1309004	1320904	1340904	1310904
M7x1,0	18	5,5	13	90°	9	⊕	1300905	-	-	-
M8x0,75	18	5,5	13	90°	9	⊕	1300906	-	-	-
M8x1,0	18	5,5	13	90°	9	⊕	1300907	1320907	1340907	1310907
	18	5,5	14	90°	9	□	1304507	-	-	-
M8x1,25	18	5,5	14	90°	9	□	1304508	-	-	-
	18	5,5	13	90°	9	⊕	1300908	1320908	-	1310908
M10x1,0	18	5,5	15	90°	11	□	1304709	-	-	-
	20	5,5	14	90°	11	⊕	1301109	1321109	1341109	1311109
	42	7	15	90°	11	□	5242092	-	-	-

¹⁾ – gwint stożkowy

¹⁾ - tapered thread

20.04.2017

1/3



ARGIP

www.argip.com.pl

tel. +48 61 872 66 02

fax +48 61 872 66 00

Kopiowanie i rozpowszechnianie bez zezwolenia zabronione
Copying and distribution prohibited without permission

Smarowniczki kulkowe ciśnieniowe z główką stożkową – kątowe 90°

wg **DIN 71412 C**
acc. to DIN 71412 C

PN 86003

Lubricating nipples – cone type; angled version 90°

Wymiary c.d.

Dimensions cont.

d ¹⁾	h	b	k	α	s	Numer kat. Art. No.				
						stal, oc. biały steel, zinc plated	stal nierdz. A1 (1.4305) stainless steel A1 (1.4305)	stal kwasoodp. A4 stainless steel A4	mosiądz brass	
M10x1,25	20	5,5	14	90°	11	⊕	1301110	-	-	-
M10x1,5	18	5,5	15	90°	11	⊕	1301111	1321111	-	-
M12x1,0	22	6,5	14	90°	14	⊕	1301412	-	-	-
M12x1,5	22	6,5	14	90°	14	⊕	1301414	-	-	-
M12x1,75	22	6,5	14	90°	14	⊕	1301415	-	-	-
M14x1,5	22	6,5	14	90°	14	⊕	1301417	-	-	-
M14x2,0	22	6,5	14	90°	14	⊕	1301419	-	-	-
R1/8, 1/8-28 BSP	18	5,5	15	90°	11	□	1304756	-	-	-
	20	5,5	14	90°	11	⊕	1301156	1321156	1341156	1311156
	42	7	15	90°	11	□	5242093	-	-	-
R1/4, 1/4-19 BSP	22	6,5	14	90°	11	⊕	1301457	1321457	1341457	1311457
R3/8, 3/8-19 BSP	20	7	19	90°	17	⊕	1301758	-	-	-
1/8-27 NPT/PTF	18	5,5	15	90°	11	□	1304767	-	-	-
1/4-18 NPT/PTF	22	6,5	14	90°	14	⊕	1301468	-	-	-
1/4-26 BSF	18	5,5	13	90°	9	⊕	1300944	1320944	-	1310944
1/4-28 NF/UNF /SAE	18	5,5	13	90°	9	⊕	1300937	1320937	-	1310937
1/4-BSW	18	5,5	13	45°	9	⊕	1300950	1320945	-	-
5/16- 22BSF	18	5,5	13	90°	9	⊕	1300945	-	-	-
5/16-24NF /UNF/SAE	18	5,5	13	90°	9	⊕	1300938	-	-	-
5/16-BSW	18	5,5	13	90°	9	⊕	1300951	-	-	-
3/8-18NPT /PTF	20	7	19	90°	11	⊕	1301760	-	-	-
3/8-BSF	20	5,5	14	90°	11	⊕	1301146	-	-	-

¹⁾ – gwint stożkowy

¹⁾ - tapered thread

20.04.2017

2/3



ARGIP

www.argip.com.pl

tel. +48 61 872 66 02

fax +48 61 872 66 00

Kopiowanie i rozpowszechnianie bez zezwolenia zabronione
Copying and distribution prohibited without permission

Smarowniczki kulkowe ciśnieniowe z główką stożkową – kątowe 90°



wg **DIN 71412 C**
acc. to DIN 71412 C

PN 86003

Lubricating nipples – cone type; angled version 90°

Wymiary c.d.

Dimensions cont.

d ¹⁾	h	b	k	α	s		Numer kat. Art. No.			
							stal, oc. biały steel, zinc plated	stal nierdz. A1 (1.4305) stainless steel A1 (1.4305)	stal kwasoodp. A4 stainless steel A4	mosiądz brass
3/8-24NF /UNF/SAE	20	5,5	14	90°	11		1301139	-	-	-
3/8-BSW	20	5,5	14	90°	11		1301152	-	-	-
1/2-20UNF /NF/SAE	22	6,5	14	90°	11		1301440	-	-	-

¹⁾ – gwint stożkowy

¹⁾ - tapered thread

Materiał:

Stal o klasie własności mechanicznych 5.8 wg ISO 898-1

Powierzchnia wg DIN 50133 o twardości min 550 HV

Głębokość hartowania: 0,08 do 0,15mm

Powłoki galwaniczne wg DIN 297-9 : A3F

Material:

Steel of 5.8 property class

Surface acc. to DIN 50133 – 550HV hardness

Depth of hardening: 0,08 to 1,15 mm

Elektroplating acc to DIN 267-9: A3F

Przykład oznaczenia smarowniczki kulkowej z gwintem M8x1, kątovej 45° forma B, wykonanej ze stali węglowej:

Smarowniczka DIN 71412 – B- 45° - M8x1 – St

Example designation of lubricating nipples with thread M8x1, angled version 45° form B, made of steel:

Lubricating nipples DIN 71412 – B-45°- M8x1 - St

